

# Turnkey System Configurations

The configurations shown below should be of assistance in finding the best solution for your application. Please refer to the SYSTEM Identifier (A,B,etc.) when reviewing the applications in the following pages.

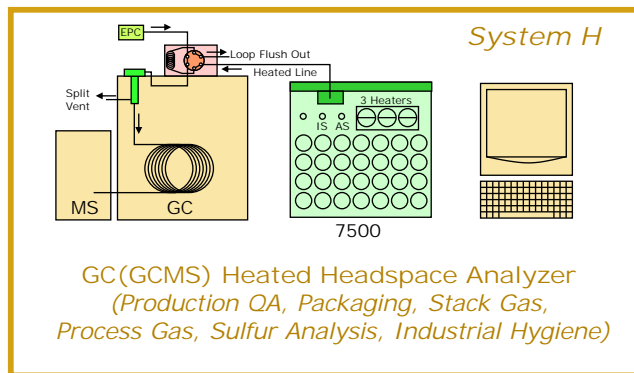
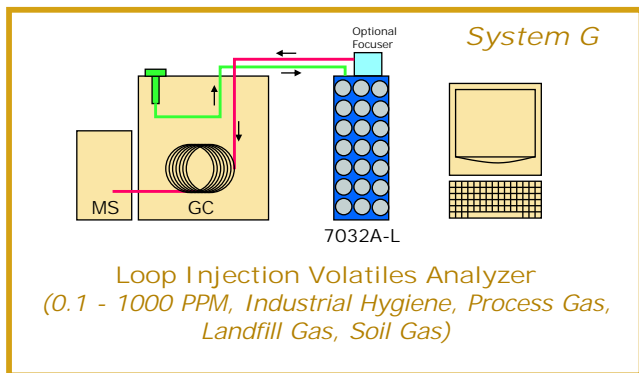
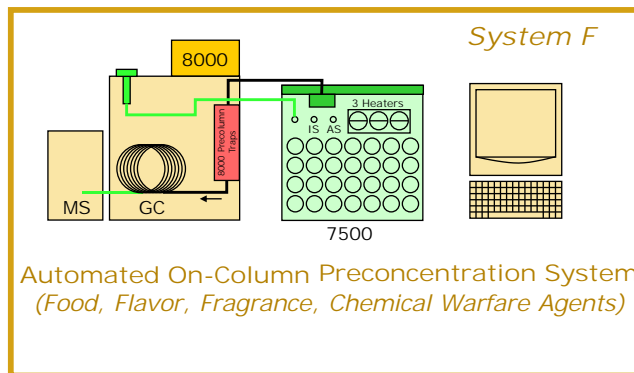
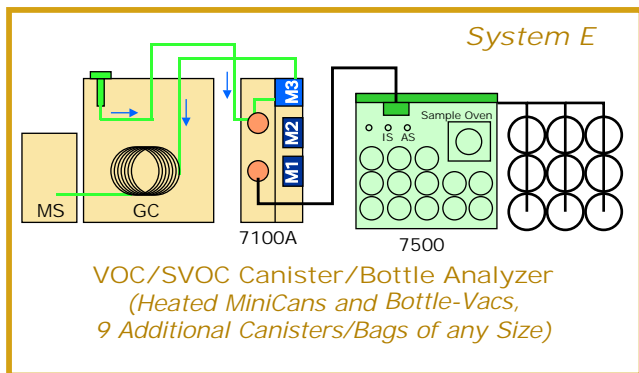
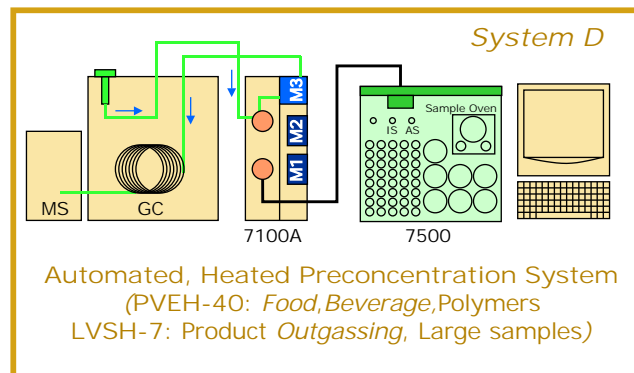
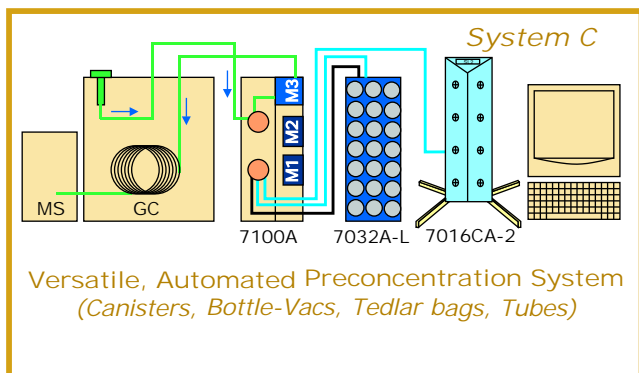
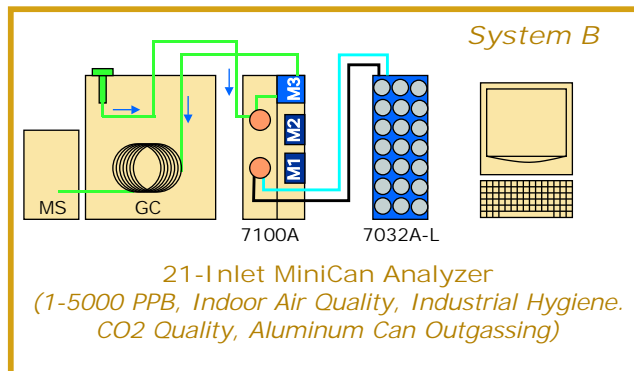
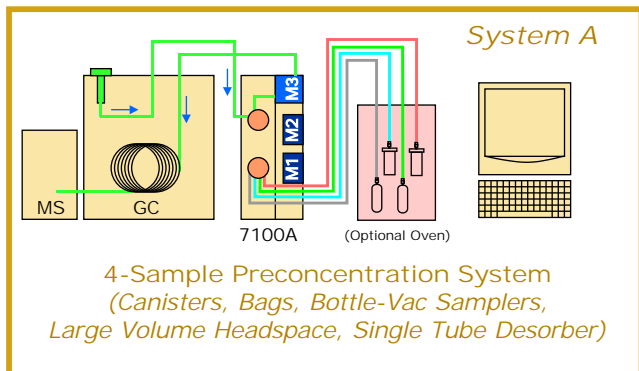

Some of the applications above can utilize single or multiple non-selective detectors in place of mass spectrometry.